

Assembly BOM

Item	Qty	Type	PriValue	SecValue	Package	Height	Reference	DigiKey		Mouser		Ali Express	
								Part Number	Manufacturer	Part Number	Manufacturer	Description	Vendor
1a	4	Resistor	49.9R	-	3.3mm	1.78mm	R23, R24, R25, R26	SFR16S0004999FR501	Vishay	-	-	-	-
1b	4	Resistor	49.9R	-	0805	0.45mm	R23, R24, R25, R26	-	-	-	-	-	-
2	2	Resistor	51R	-	3.3mm	1.78mm	R20, R21	RNMF14FTC51R0	Stackpole	-	-	-	-
3	3	Resistor	100R	-	3.3mm	1.78mm	R3, R4, R7	RNMF14FTC100R	Stackpole	-	-	-	-
4	2	Resistor	1K	-	3.3mm	1.78mm	R16, R19	RNMF14FTC1K00	Stackpole	-	-	-	-
5	4	Resistor	1.5K	-	3.3mm	1.78mm	R2, R8, R9, R12	RNMF14FTC1K50	Stackpole	-	-	-	-
6	2	Resistor	2K	-	3.3mm	1.78mm	R27, R28	RNMF14FTC2K00	Stackpole	-	-	-	-
7a	1	Resistor	2.32K	-	3.3mm	1.78mm	R14	MBA02040C2321FC10	Vishay	-	-	-	-
7b	1	Resistor	2.32	-	0805	0.45mm	R14	-	-	-	-	-	-
8	3	Resistor	3K	-	3.3mm	1.78mm	R1, R5, R6	RNMF14FTC3K00	Stackpole	-	-	-	-
9	6	Resistor	10K	-	3.3mm	1.78mm	R10, R11, R13, R15, R17, R22	RNMF14FTC10K0	Stackpole	-	-	-	-
10	1	Resistor	47K	-	3.3mm	1.78mm	R18	RNMF14FTC47K0	Stackpole	-	-	-	-
11	1	Diode Schottky	1A	60V	DO-41	2.5mm	VD7	MBR160G	ON Semi.	SR106 A0G	Taiwan Semi.	-	-
12	7	Diode Signal	0.2A	100V	DO-35	1.78mm	VD1, VD2, VD3, VD4, VD5, VD6, VD7	1N4148	ON Semi.	1N4148	On Semi.	-	-
13	1	SD Card Socket	-	-	-	2.75mm	XS1	GSD090144HR	Amphenol ICC	GSD090144HR	Amphenol ICC	-	-
14	1	Crystal	20MHz	18pF	HC-49	3.75mm	ZQ2	ABL-20.000MHZ-N2X-	Abracon	ECS-200-18-4X-CKM	ECS Inc.	-	-
15	1	Crystal	25MHz	18pF	HC-49	3.75mm	ZQ3	ABL-25.000MHZ-N2XF	Abracon	ECS-250-18-4X-CKM	ECS Inc.	-	-
16	2	Headphone Jack	R.R.T.	-	-	5mm	XP2, XP10	-	-	-	-	PJ-313	SuperMicro Store
17	1	Socket	4pin	-	DIP8 0.3"	5.08mm	G2	1108800	Aries	1108800	Aries	-	-
18	3	Socket	8pin	-	DIP8 0.3"	5.08mm	DS2, DA3, DD11	4808-3000-CP	3M	4808-3000-CP	3M	-	-
19	2	Socket	14pin	-	DIP14 0.3	5.08mm	DD3, DD10	4814-3000-CP	3M	4814-3000-CP	3M	-	-
20	6	Socket	16pin	-	DIP16 0.3	5.08mm	DS1 x2, DD2, DD4, DD7, DD9	4816-3000-CP	3M	4816-3000-CP	3M	-	-
21	3	Socket	28pin	-	DIP28 0.3	5.08mm	DD5, DD6, DD8	4828-3004-CP	3M	4828-3004-CP	3M	-	-
22	1	Socket	40pin	-	DIP40 0.6	5.08mm	DD1	4840-6000-CP	3M	4840-6000-CP	3M	-	-
23	3	Resistor Array Bu:	2.2K x4	-	SIP5	5.08mm	DR1, DR2, DR4	4605X-101-222LF	Bourns	4605X-101-222LF	Bourns	-	-
24	1	Resistor Array Bu:	2.2K x3	-	SIP4	5.08mm	DR3	4604X-101-222LF	Bourns	4604X-101-222LF	Bourns	-	-
25	1	LED	Red	-	T3	5.5mm	HL1	WP908A8ID	Kingbright	WP908A8ID	Kingbright	-	-
26	1	Crystal	32.768kHz	6pF	can	6.2mm	ZQ1	ECS-327-6-13X	ECS Inc.	ECS-327-6-13X	ECS Inc.	-	-
27	1	LED	Green	RA	T3	7.3mm	HL2	WP934CB/GD	Kingbright	WP934CB/GD	Kingbright	-	-
28	2	LED	Yellow	RA	T3	7.3mm	HL3, HL5	WP934CB/YD	Kingbright	WP934CB/YD	Kingbright	-	-
29	1	LED	Red	RA	T3	7.3mm	HL4	WP934CB/ID	Kingbright	WP934CB/ID	Kingbright	-	-
30	22	Capacitor Cer.	100nF	50V	2.5mm	7.36mm	C1, C3, C4, C5, C6-I, C6-II, C7, C8, C9, C10, C11, C12, C16, C19, C21, C28, C31, C33, C34, C38, C39, C40	C320C104K5R5TA	Kemet	K104M15X7RF53K2	Vishay	-	-
31	4	Capacitor Cer.	22pF COG	50V	2.5mm	7.36mm	C22, C23, C35, C36	C315C220K5G5TA	Kemet	K220J15C0GF53L2	Vishay	-	-
32	5	Capacitor Cer.	1uF	25V	2.5mm	7.36mm	C24, C25, C26, C27, C29	C315C105K3R5TA	Kemet	K105220Y5VF5TL2	Vishay	-	-
33	1	Inductor	100uH	0.35A	5mm	7.5mm	L2	11R104C	Murata	11R104C	Murata	-	-
34	1	Capacitor Ele.	1uF	50V	4mm	7mm	C30	-	-	50Nw71MEFC4X7	Rubycon	-	-
35	1	Transistor PNP	0.1A	50V	TO-92	7mm	VT1	BC556BTA	ON Semi.	BC556BTA	ON Semi.	-	-
36	1	Regulator	3.3V	0.1A	TO-92	7mm	DA1	L78L33ACZ	STMicro.	L78L33ACZ	STMicro.	-	-
37a	1	Regulator	3.3V	0.8A	SOT-223	-	DA2	LDL1117S33R	STMicro.	AZ1117CR-3.3TRG1	Diodes Inc.	-	-
37b	1	Regulator	3.3V	0.8A	TO-220	18.5mm	DA2	-	-	-	-	-	-
38	1	Capacitor Ele.	10uF	16V	5mm	12.5mm	C37	8.6001E+11	Würth	8.6001E+11	Würth	-	-
39	5	Capacitor Ele.	100uF	16V	5mm	12.5mm	C13, C14, C15, C20, C32	8.6001E+11	Würth	8.6001E+11	Würth	-	-
40	1	Capacitor Ele.	1000uF	16V	8mm	16mm	C2	8.6016E+11	Würth	8.6016E+11	Würth	-	-
41	1	Inductor	100uH	0.66A	8mm	13mm	L1	RLH0912-101KBRL	Bourns	RLH0912-101KBRL	Bourns	-	-
42	1	DIN 6 Jack	-	RA	-	13mm	XP7	MD-60SM	CUI	MD-60SM	CUI	-	-
43	1	DSUB 15HD Jack	-	RA	-	12.5mm	XP8	6.18015E+11	Würth	6.18015E+11	Würth	-	-
44	1	Ethernet Jack	Magnetics	RA	-	13.5mm	A2	-	HanRun	-	HanRun	HR911105A	StarLanguage Store
45	1	PolySwitch	1.1A	24V	-	18mm	F1	0ZRR0110FF1A	Bel Fuse	0ZRR0110FF1A	Bel Fuse	-	-
46	1	Battery Holder	CR2032	V	-	22mm	G1	BH-125A-1	Adam Tech	S8401-46	Harwin	-	-
47	1	Buzzer	6V	2.3kHz	12mm	9.7mm	HA1	AI-1223-TWT-5V-6-R	PUI Audio	AI-1223-TWT-5V-R	PUI Audio	-	-
48	1	Oscillator	25.175MHz	5V	DIP8 0.3"	socketted	G1	-	-	MXO45HS-3C-25M17	CTS	-	-
49	1	MCU	-	5V	DIP40 0.6	socketted	DD1	ATMEGA1284-PU	Atmel	ATMEGA1284-PU	Atmel	-	-
50	2	MCU	-	5V	DIP28 0.3	socketted	DD5, DD8	ATMEGA328P-PU	Atmel	ATMEGA328P-PU	Atmel	-	-
51	1	MCU	-	5V	DIP8 0.3"	socketted	DD11	ATTINY13A-PU-ND	Atmel	ATTINY13A-PU-ND	Atmel	-	-
52	1	Logic	Ripple 4b x2	-	DIP14 0.3	socketted	DD10	CD74HC393E	TI	CD74HC393E	TI	-	-
53	1	RTCC	Serial	5V	DIP16 0.3	socketted	DD4	DS1305+	Maxim	DS1305+	Maxim	-	-
54	1	Line Driver	RS232	5V	DIP16 0.3	socketted	DD7	MAX232CPE+	AD/Maxim	MAX232CPE+	AD/Maxim	-	-
55	1	Logic	NAND x4	5V	DIP14 0.3	socketted	DD3	SN74HC00N	TI	SN74HC00N	TI	-	-
56	1	Logic	Shift 8b > 1b	5V	DIP16 0.3	socketted	DD9	SN74HC166N	TI	SN74HC166N	TI	-	-
57	1	EEPROM	1Mb x1	5V	DIP8 0.3"	socketted	DS2	25LC1024-I/P	Microchip	25AA1024-I/P	Microchip	-	-
58	1	Logic	deMUX 3b > 15V	-	DIP16 0.3	socketted	DD2	TC74HC138APF	Toshiba	TC74HC138APF	Toshiba	-	-
59	1	Amplifier	1W	-	DIP8 0.3"	socketted	DA3	-	NXP	-	NXP	TDA7052A	SusStore
60	1	Ethernet MAC/PH	-	3.3V	DIP28 0.3	socketted	DD6	ENC28J60-I/SP	Microchip	ENC28J60-I/SP	Microchip	-	-
61a	1	SRAM	512Kb x8	5V	DIP32 0.3	socketted	DS1	-	Winbond	-	Winbond	W24512AK-1	Shop911114203 Store
61b	1	SRAM	512Kb x8	5V	DIP32 0.3	socketted	DS1	-	ISSI	-	ISSI	IS61C512-15I	LAKE Store
62	6	Connector	Header	2pin	0.100"	8.54mm	X1, XP4, XP5, XP9, XP11, ?	61300211121	Würth	61300211121	Würth	-	-
63	2	Connector	Header	3pin	0.100"	8.54mm	XP1, XP2	61300311121	Würth	61300311121	Würth	-	-
64	2	Connector	Header	6pin	0.100"	8.54mm	XP3, XP6	61300611121	Würth	61300611121	Würth	-	-

## Assembly BOM

Item	Qty	Type	Value	Value	Package	Height	Reference
1a	4	Resistor	49.9R	-	3.3mm	1.78mm	R23, R24, R25, R26
1b	4	Resistor	49.9R	-	0805	0.45mm	R23, R24, R25, R26
2	2	Resistor	51R	-	3.3mm	1.78mm	R20, R21
3	3	Resistor	100R	-	3.3mm	1.78mm	R3, R4, R7
4	2	Resistor	1K	-	3.3mm	1.78mm	R16, R19
5	4	Resistor	1.5K	-	3.3mm	1.78mm	R2, R8, R9, R12

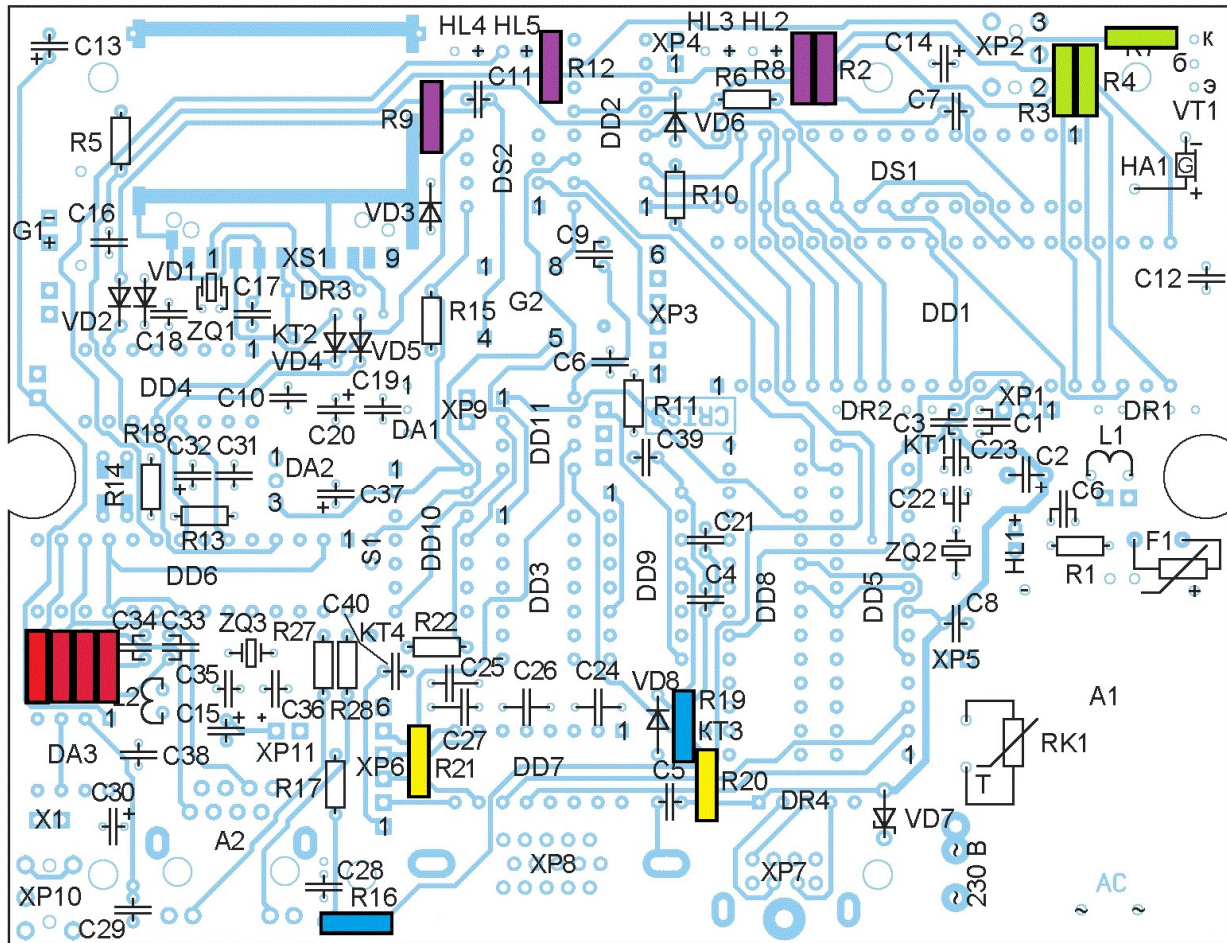

### Assembly BOM

Item	Qty	Type	Value	Value	Package	Height	Reference
6	2	Resistor 2K	-	3.3mm	1.78mm		R27, R28
7a	1	Resistor 2.32K	-	3.3mm	1.78mm		R14
7b	1	Resistor 2.32	-	0805	0.45mm		R14
8	3	Resistor 3K	-	3.3mm	1.78mm		R1, R5, R6
9	6	Resistor 10K	-	3.3mm	1.78mm		R10, R11, R13, R15, R17, R22
10	1	Resistor 47K	-	3.3mm	1.78mm		R18

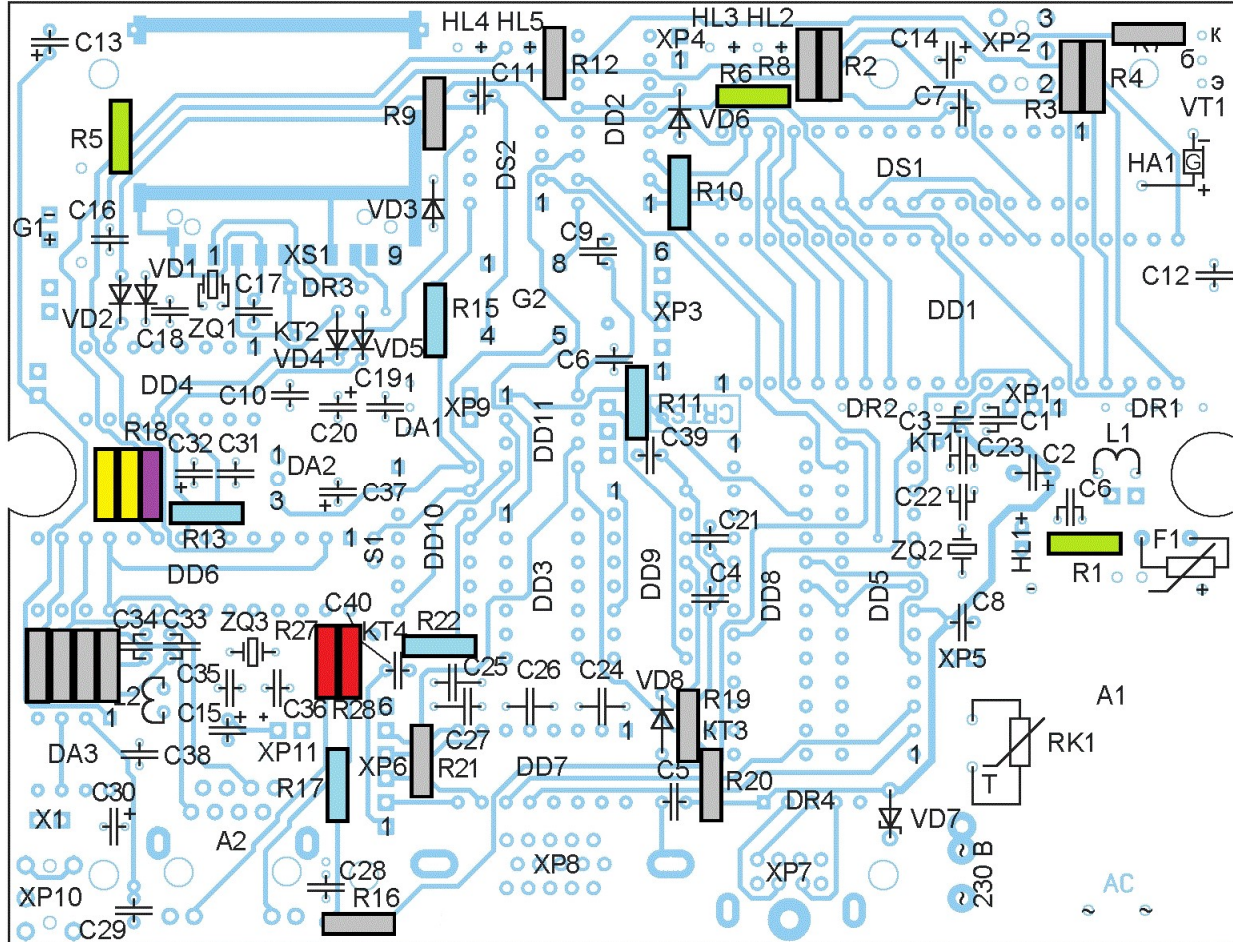

### Assembly BOM

Item	Qty	Type	riValue	cValue	Package	Height	Reference
11	1	Diode Schottky 1A	60V	DO-41	2.5mm		VD7
12	7	Diode Signal	0.2A	100V DO-35	1.78mm		VD1, VD2, VD3, VD4, VD5, VD6, VD8
13	1	SD Card Socke-	-	-	2.75mm		XS1
14	1	Crystal	20MHz 18pF	HC-49	3.75mm		ZQ2
15	1	Crystal	25MHz 18pF	HC-49	3.75mm		ZQ3

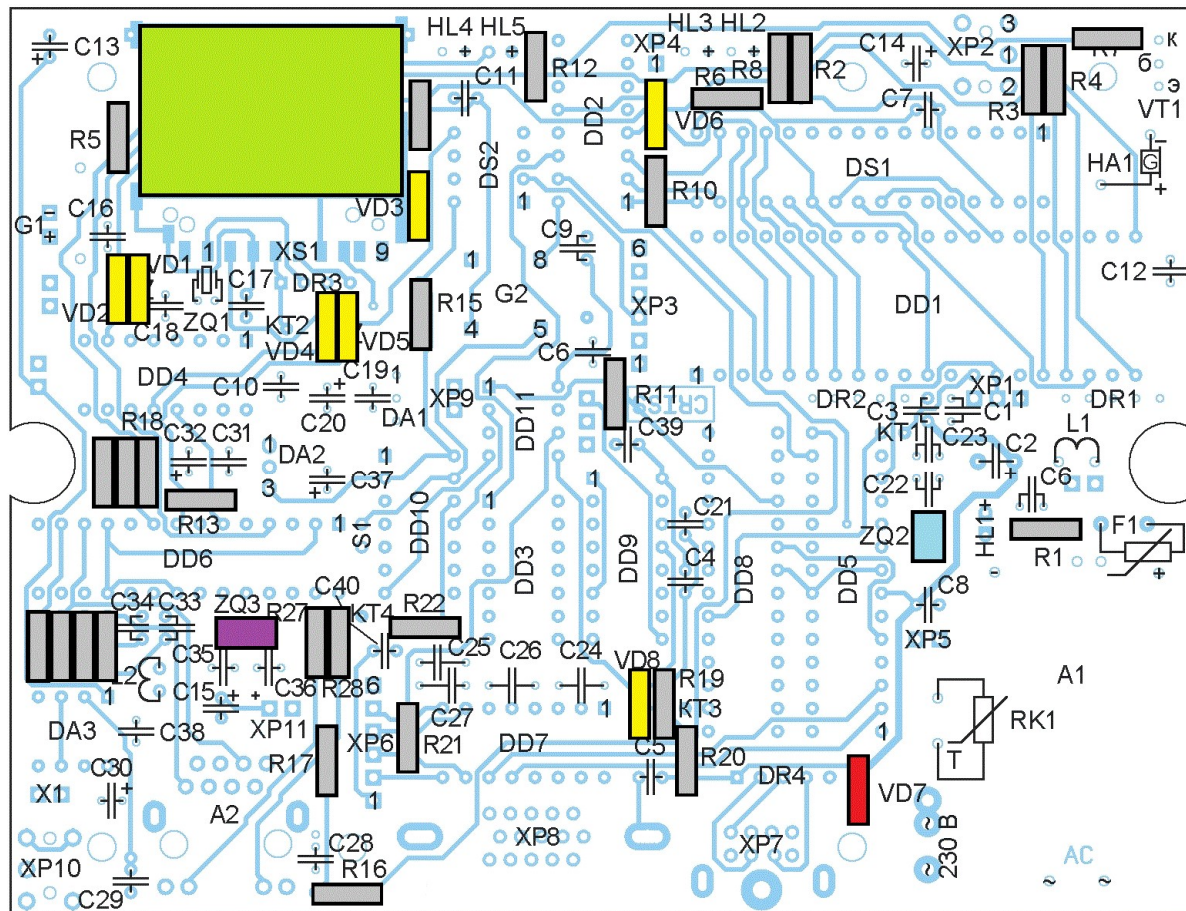

## Assembly BOM

Item	Qty	Type	Value	Value	Package	Height	Reference
16	2	Headphone Jac	R.R.T. -	-	5mm		XP2, XP10
17	1	Socket	4pin	-	DIP8 0.3"	5.08mm	G2
18	3	Socket	8pin	-	DIP8 0.3"	5.08mm	DS2, DA3, DD11
19	2	Socket	14pin	-	DIP14 0.3"	5.08mm	DD3, DD10
20	6	Socket	16pin	-	DIP16 0.3"	5.08mm	DS1 x2, DD2, DD4, DD7, DD9

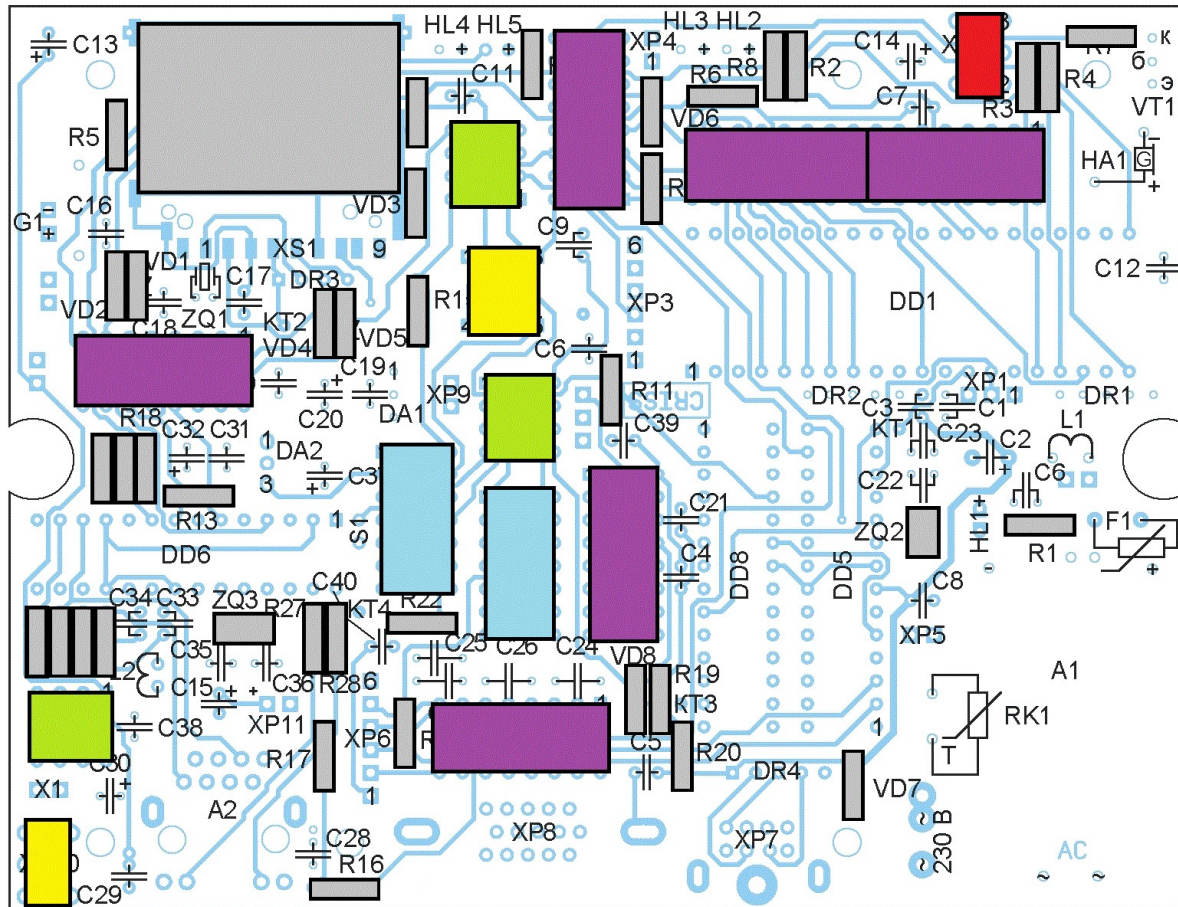

**Assembly BOM**

Item	Qty	Type	riValue	cValue	Package	Height	Reference
21	3	Socket	28pin	-	DIP28 0.3'	5.08mm	DD5, DD6, DD8
22	1	Socket	40pin	-	DIP40 0.6'	5.08mm	DD1
23	3	Resistor Array Bus 2.2K x4	-	-	SIP5	5.08mm	DR1, DR2, DR4
24	1	Resistor Array Bus 2.2K x3	-	-	SIP4	5.08mm	DR3
25	1	LED	Red	-	T3	5.5mm	HL1

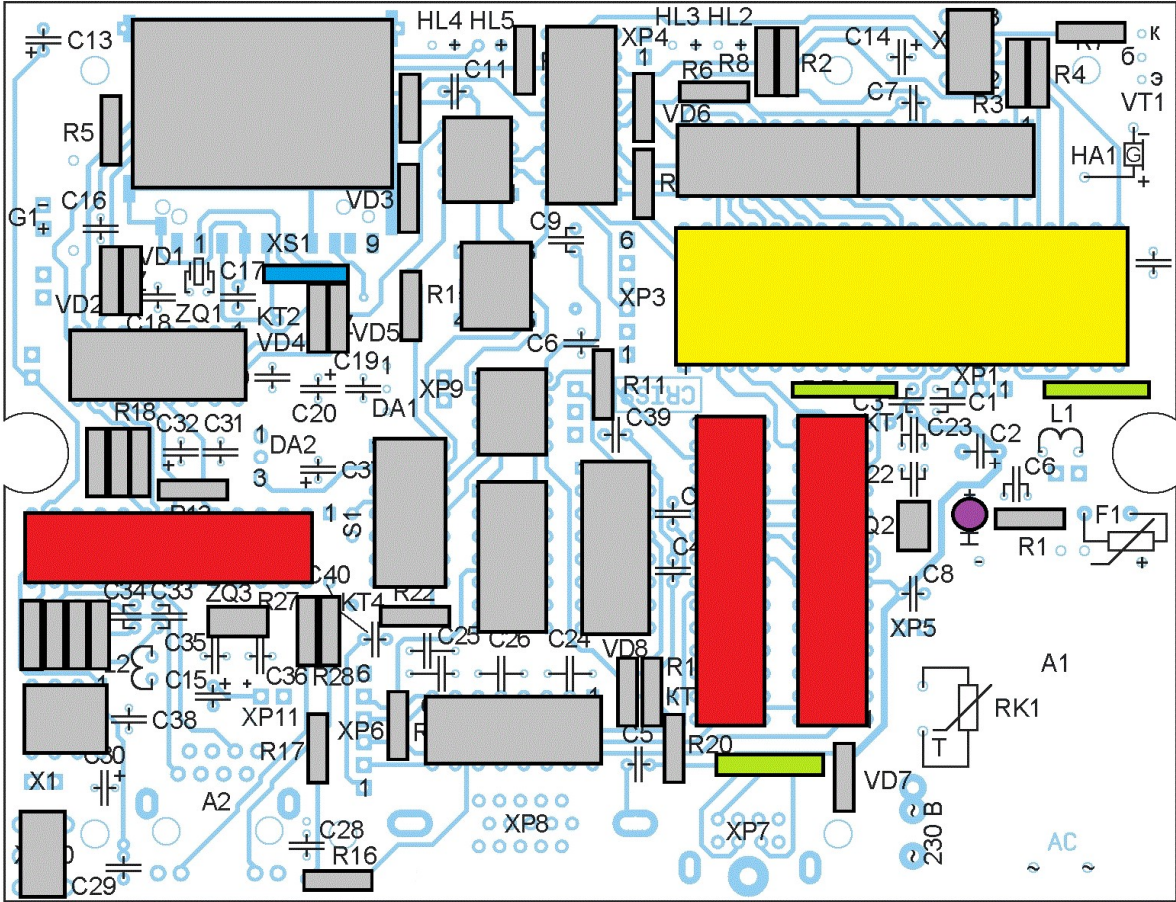

**Assembly BOM**

Item	Qty	Type	PriValue	cValu	Package	Height	Reference
26	1	Crystal	32.768kHz	6pF	can	6.2mm	ZQ1
27	1	LED	Green	RA	T3	7.3mm	HL2
28	2	LED	Yellow	RA	T3	7.3mm	HL3, HL5
29	1	LED	Red	RA	T3	7.3mm	HL4
30	22	Capacitor Cer	100nF	50V	2.5mm	7.36mm	C1, C3, C4, C5, C6-I, C6-II, C7,

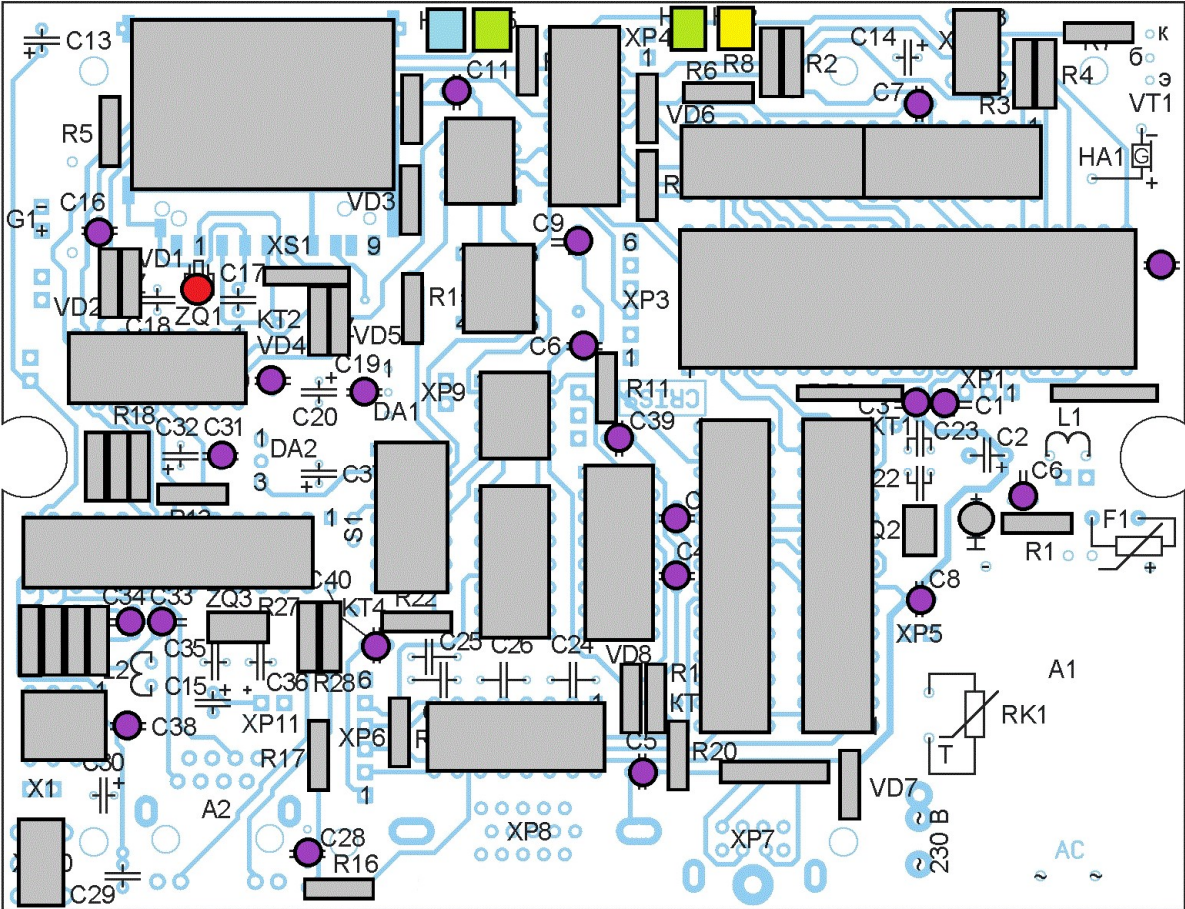

### Assembly BOM

Item	Qty	Type	PriValue	cValue	Package	Height	Reference
31	4	Capacitor Cer. 22pF COC 50V		2.5mm	7.36mm		C22, C23, C35, C36
32	5	Capacitor Cer. 1uF	25V	2.5mm	7.36mm		C24, C25, C26, C27, C29
33	1	Inductor	100uH	0.35A	5mm	7.5mm	L2
34	1	Capacitor Ele. 1uF	50V	4mm	7mm		C30
35	1	Transistor PNI0.1A	50V	TO-92	7mm		VT1

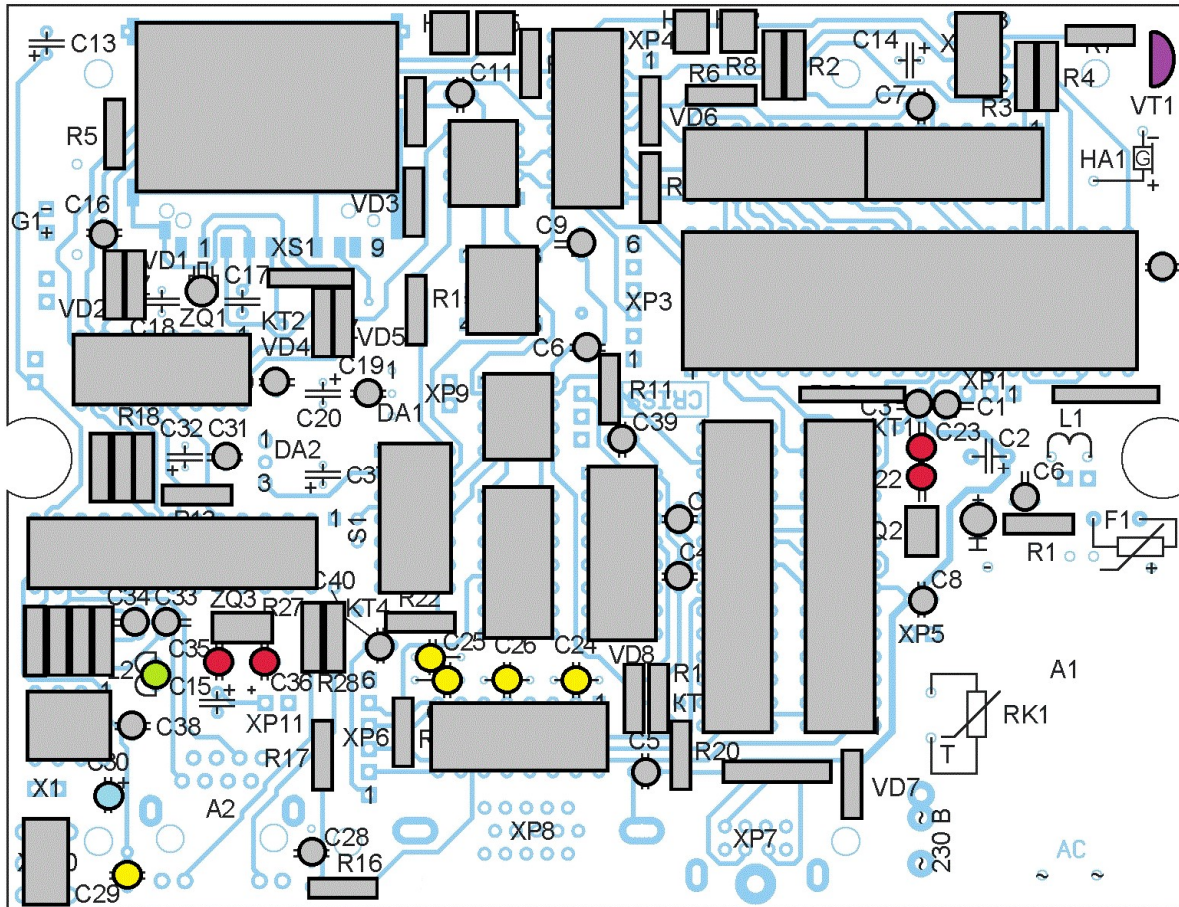



### Assembly BOM

Item	Qty	Type	PriValue	cValue	Package	Height	Reference
36	1	Regulator	3.3V	0.1A	TO-92	7mm	DA1
37a	1	Regulator	3.3V	0.8A	SOT-223 -		DA2
37b	1	Regulator	3.3V	0.8A	TO-220	18.5mm	DA2
38	1	Capacitor Ele.	10uF	16V	5mm	12.5mm	C37
39	5	Capacitor Ele.	100uF	16V	5mm	12.5mm	C13, C14, C15, C20, C32
40	1	Capacitor Ele.	1000uF	16V	8mm	16mm	C2

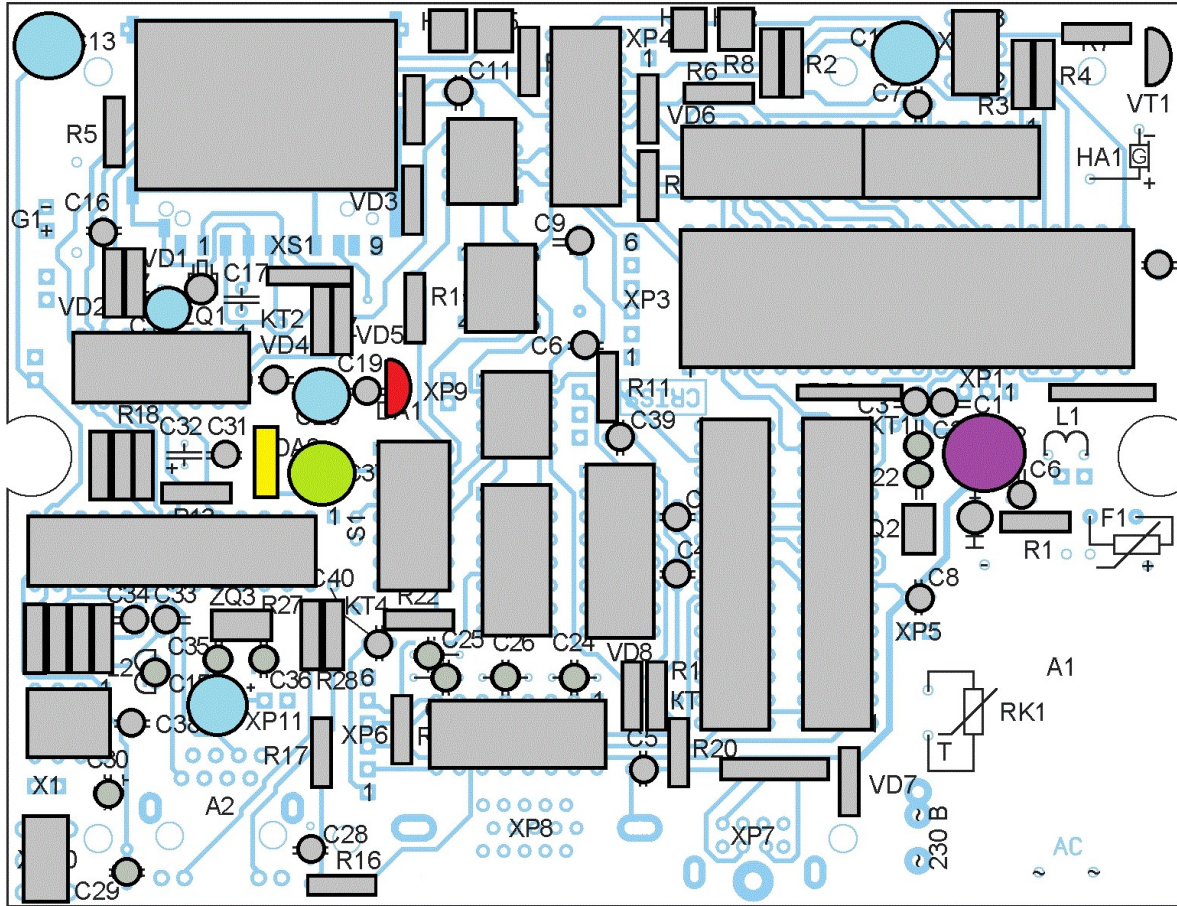

### Assembly BOM

Item	Qty	Type	PriValue	cValue	Package	Height	Reference
41	1	Inductor	100uH	0.66A	8mm	13mm	L1
42	1	DIN 6 Jack	-	RA	-	13mm	XP7
43	1	DSUB 15HD J-	-	RA	-	12.5mm	XP8
44	1	Ethernet Jack	Magnetics	RA	-	13.5mm	A2
45	1	PolySwitch	1.1A	24V	-	18mm	F1

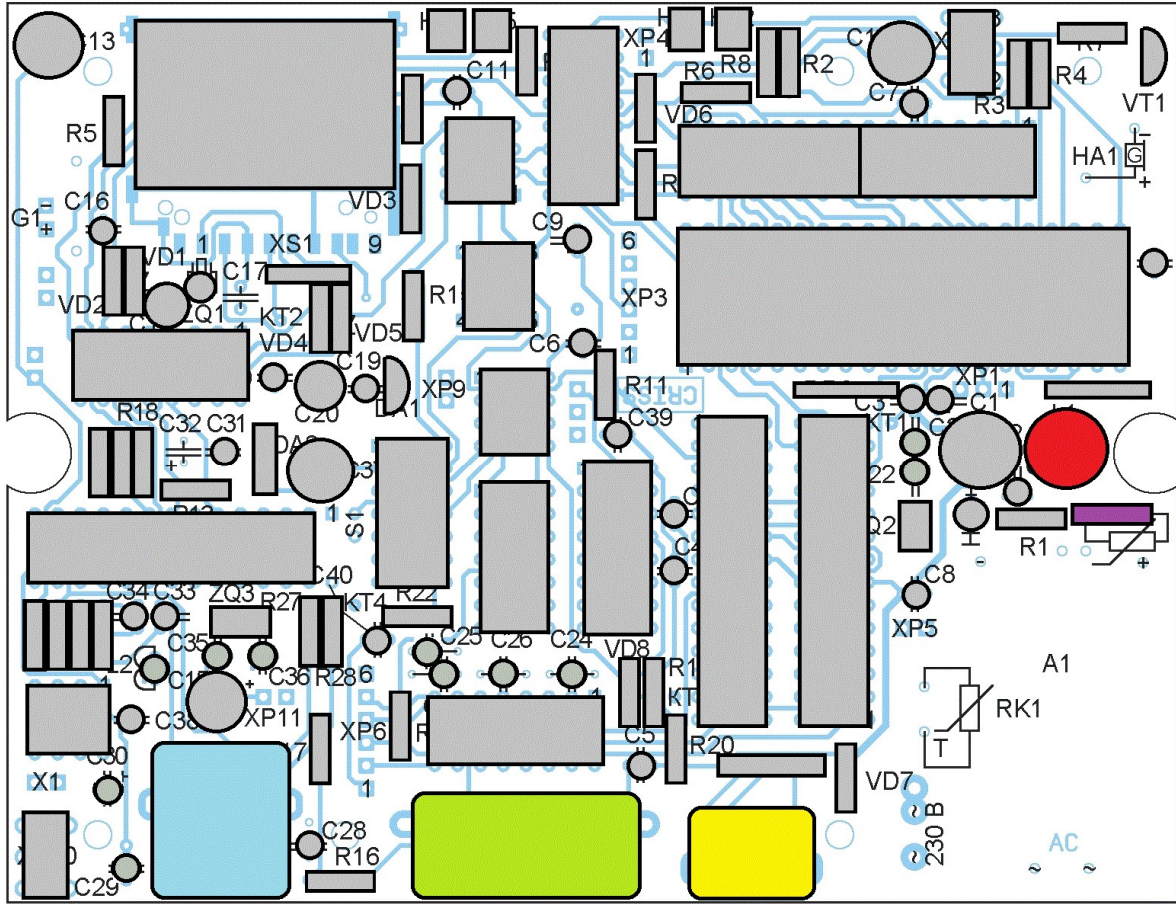

### Assembly BOM

Item	Qty	Type	PriValue	cValue	Package	Height	Reference
46	1	Battery Holder CR2032	V	-		22mm	G1
47	1	Buzzer	6V	2.3kHz	12mm	9.7mm	HA1

